

Wolverine Dressing Jig Instructions

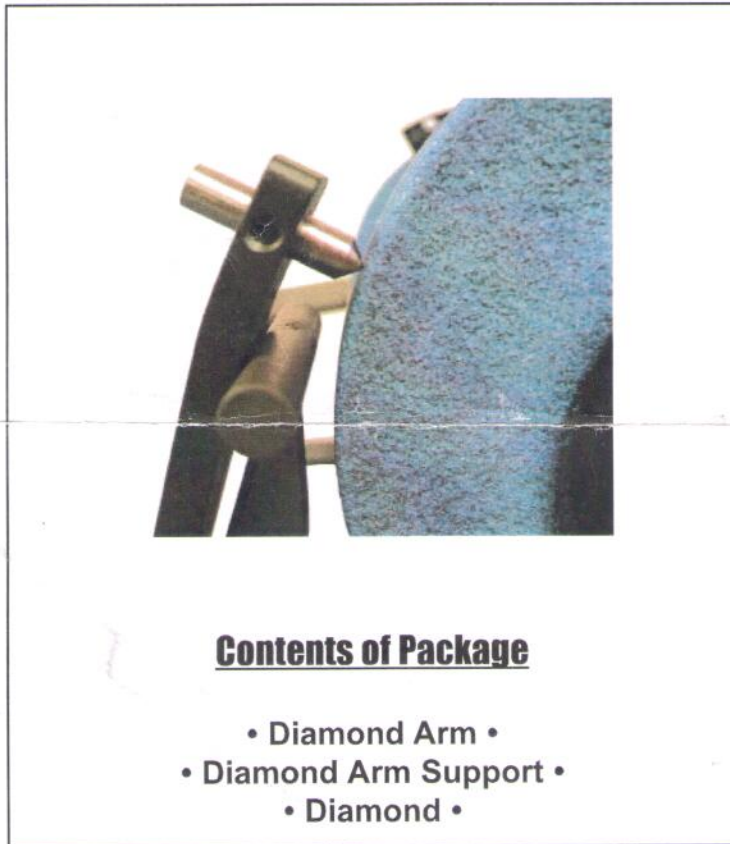

Important

This Jig requires the *Oneway Wolverine Grinding Jig* to be installed on the grinder prior to using this system.

Mounting the Diamond

Please read the supplied sheet "How to use Diamond Dressing Tools". These instructions explain the importance of having a negative lead angle on the diamond.

Set the diamond in the hole of the dressing arm.

Setting up the Dresser

1. Mount the base as described in the Grinding Jig Instructions. Please note that if you are using a 6" grinder, it may be necessary to mount the grinder on a board approx. 1" thick.
2. With your grinder turned off, put the support arm into the base (see Fig. 1). Put the adjusting screw into the hole in the dressing arm support and lay the body of the dressing arm on the round bar of the support arm (see Fig. 1). Move the support arm in or out until the diamond is just clear of the wheel.
3. Clamp the support arm in place and spin the wheel to make sure that the diamond does not touch the wheel. Use the fine adjust knob to move the diamond in or out until the diamond just clears the wheel.

Important: Be sure to continue rotating the wheel by hand to be sure there are no high spots on the wheel, and to move the diamond back and forth across the wheel to avoid possible high spots on the edges.

Dressing your Grinding Wheels

Once you are certain the diamond will not touch your wheel, turn on the grinder. Hold the dressing arm down firmly and turn the adjusting knob to move the diamond into the wheel. After turning the knob 1/4 turn, move the diamond back and forth across the wheel.

Warning: Never turn the adjusting knob more than 1/4 turn without making a dressing pass across the wheel. This will ensure that you do not damage your diamond by trying to remove too much material from your wheel at once.

Be sure to feed off the wheel on both sides. It should take between 1 to 5 seconds to dress across the face of your wheel. Continue dressing until the wheel is clean, round, free of glaze, and a uniform color.

Points to Remember

1. The diamond is fragile and can be knocked out of the mounted point.
2. Use constant, but not excessive, pressure to hold the dressing arm down against the support arm.
3. Never turn the adjusting knob more than 1/4 turn between dressing passes.
4. Grinding wheels are designed for specific applications. If you follow the instructions here, you should get good results from your wheel. If you don't, here are some suggestions:
 - Dress across the face a little faster and your wheel will cut a little more freely.
 - Dress across the face a little slower and your wheel will give a better finish.
 - Consider buying a wheel suited to your grinding requirements. The ONEWAY dresser will allow you to keep your wheel a lot longer and makes an expensive wheel a much better investment.

Manufacturers Warranty

This Oneway product is backed by a warranty period of **5 years** from the date of purchase.

Oneway hereby agrees to repair or replace, any defects due to faulty material or workmanship, provided that:

1. The warranty period has not elapsed. Proof of purchase date (sales receipt etc.) is required prior to any repair taking place.
2. The product has not been altered or modified in any way.
3. The product has not been subjected to misuse, abuse, negligence, or was not used strictly in accordance with these instructions.
4. Transportation costs incurred in returning the product to Oneway Manufacturing is pre-paid by the customer.

This warranty does not cover any costs or damages arising directly or indirectly from the operation of this product.

No other guarantee, written or verbal, is authorized by Oneway Manufacturing.

Our policy is one of continuous improvement. We therefore reserve the right to change the specification and/or design without notice.

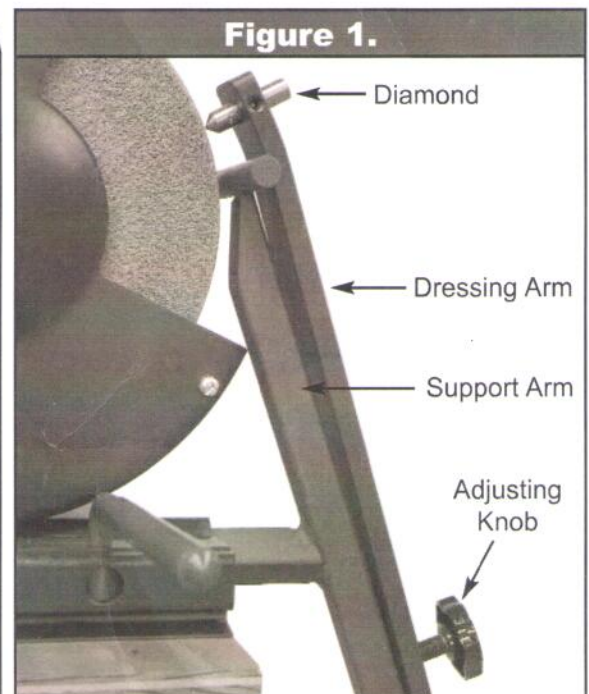

HOW TO USE DIAMOND DRESSING TOOLS

The effectiveness of Diamond Tools is in direct proportion to the care given them in maintaining their sharpness. The Diamond Dresser is just like a cutting tool made of steel. It must be obvious that dull stones crush and glaze the wheel face, loading the pores with wheel cuttings, and producing a dull wheel.

Therefore, it is necessary to turn the Dresser in its hole frequently, in order to expose a sharp cutting point on the Diamond. To ensure a sharp cutting edge, turn the Diamond as soon as a flat has developed.

Avoid subjecting the Diamond to sudden shock or blows, such as bumping it against the edge or face of the wheel. Although the Diamond is extremely hard, it is also brittle, and therefore apt to fracture under shock.

Be sure the Diamond Tool is rigidly supported, with a minimum amount of overhand, and that all sources of vibration from the grinding machine itself have been eliminated. Otherwise, chattery finishes and ruined Diamonds are bound to follow.

Avoid Overheating

Because the heat generated when dressing grinding wheels adversely affects diamonds, overheating of the setting may result in costly diamond breakage or even total loss.

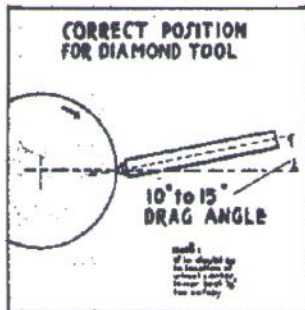

TRUING & DRESSING

WHAT IS THE CORRECT POSITION FOR THE DIAMOND TOOL?

It should be mounted at an angle to the wheel face, with the angle pointing in the same direction as the grinding wheel travel, to prevent gouging the wheel face. This is sometimes called the 'drag' angle, and it should be between 10° and 15°. Too much angle will grind away the metal holding the diamond; too flat an angle will tend to wear a large flatpoint on the diamond.

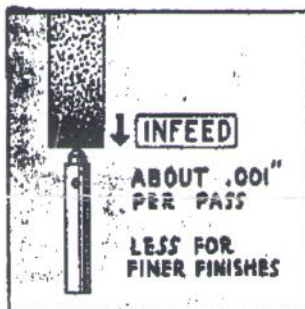

WHAT IS THE PROPER DEPTH OF CUT TO TAKE WITH THE DIAMOND?

Take light cuts - about .001" at each pass, until wheel is perfectly round. This should leave a surface satisfactory for roughing. For finer finishes, reduce the wheel infeed and for the finest finish, take several passes with the diamond across the wheel without any infeed. Deep cuts are apt to leave diamond marks on the wheel, heat the diamond excessively, and cause it to wear rapidly.



SHOULD WHEELS BE DRESSED WET OR DRY?

Dress under the same conditions as when grinding. If grinding wet, dress wet; if grinding dry, dress dry. If the dressing is done wet, use plenty of coolant directed on the diamond at the point of contact with the wheel. Turn on the coolant before the diamond is brought up to the wheel. If the dressing is done dry, give the diamond time to cool off between passes. Never allow diamond to touch stationary wheel when making adjustments, as this will lead to fractures of the diamond.

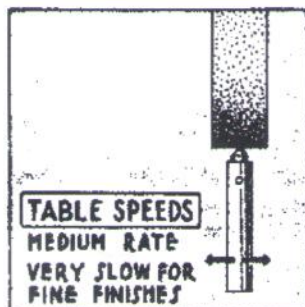

HOW FAST SHOULD THE DIAMOND BE TRAVERSED ACROSS THE WHEEL?

This depends on the grain and grade of the wheel and the finish required. A slow traverse gives a high finish, but if too slow, it will glaze the wheel. A fast traverse produces a free-cutting wheel, but if too fast, may leave 'diamond marks' on the wheel, which will be transferred to the work. In general, employ a medium traverse for rough grinding and a slow traverse for finer finishes.